

# Chair Rail Moldings

---

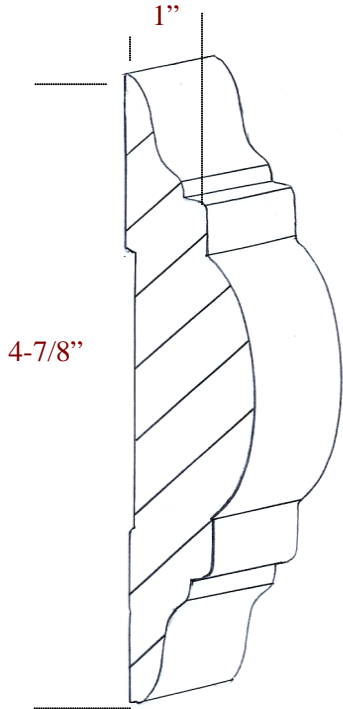

C-101

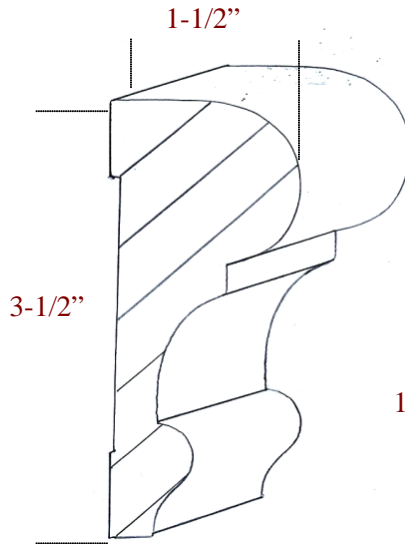

C-102

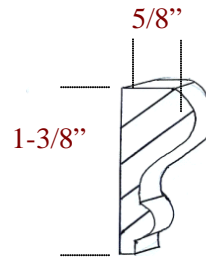

C-103

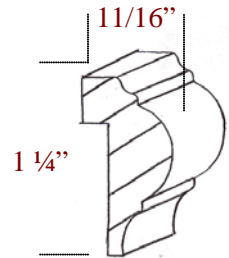

C-104

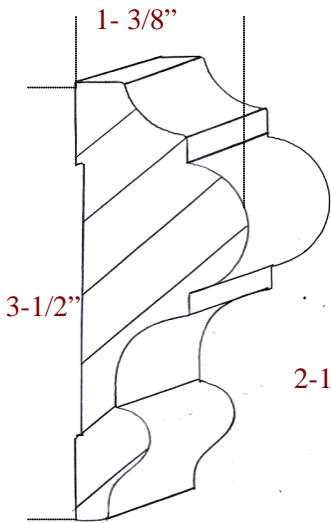

C-105

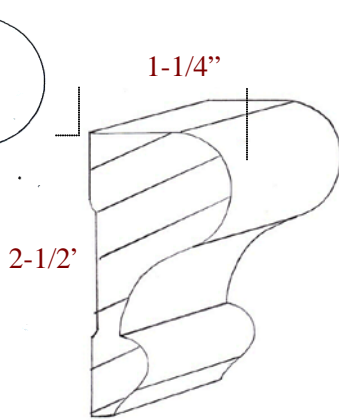

C-106

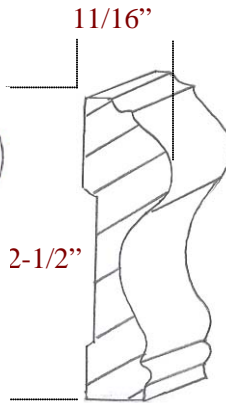

C-107

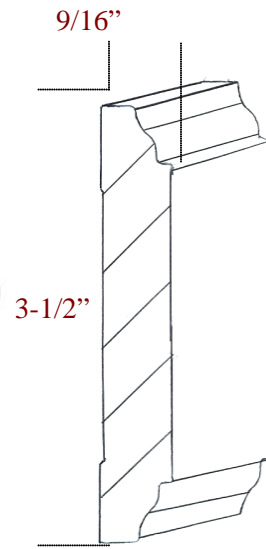

C-108

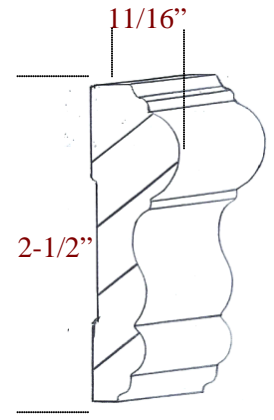

S-109  
Colonial

---

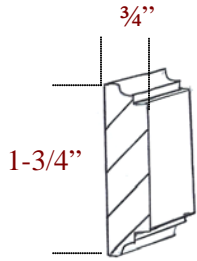
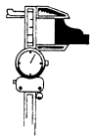

C-110

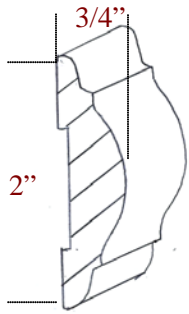

C-111

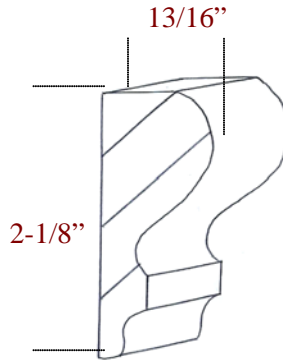

C-112

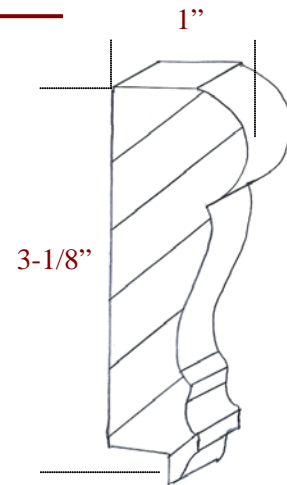

C-113

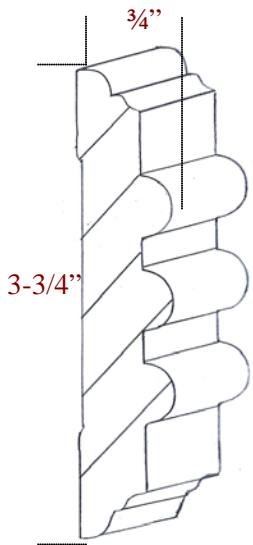

C-114

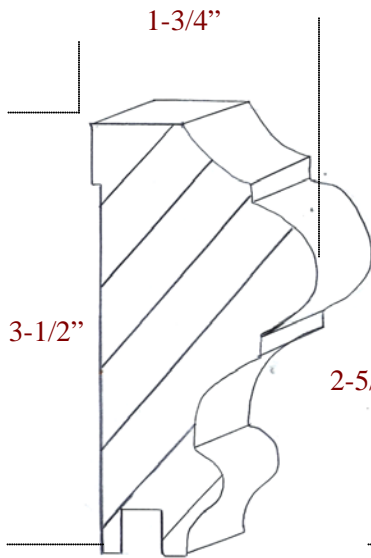

C-115

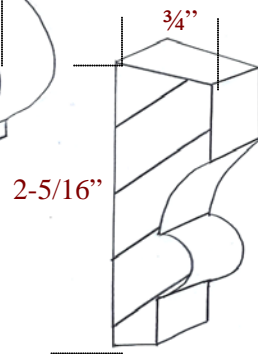

C-116

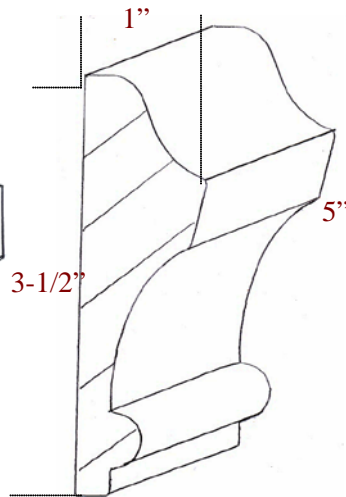

C-117

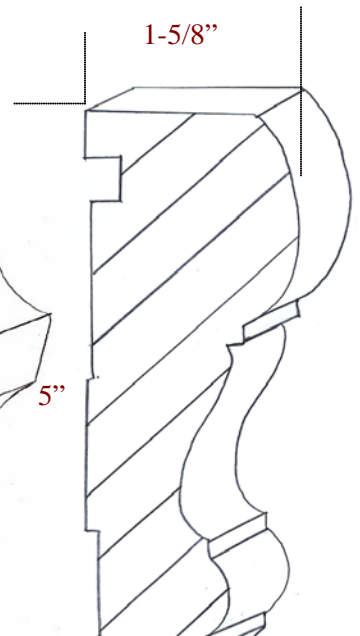

C-118

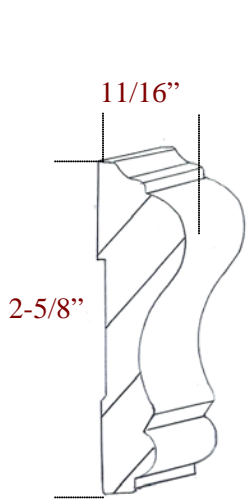
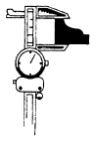

C-119  
Victorian

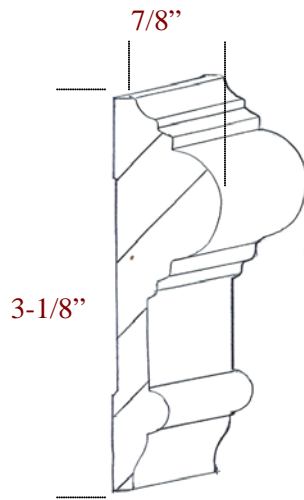

C-120

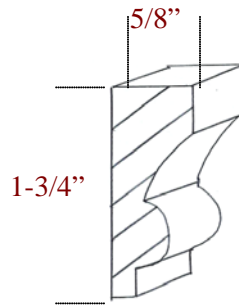

C-122

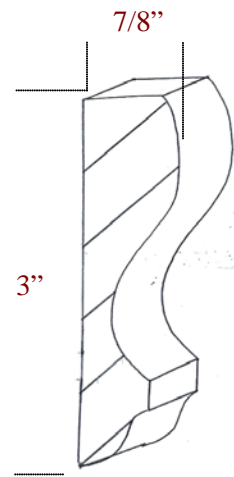

C-123

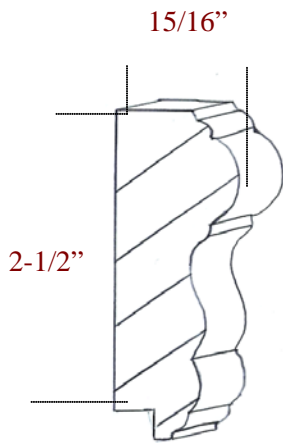

C-125

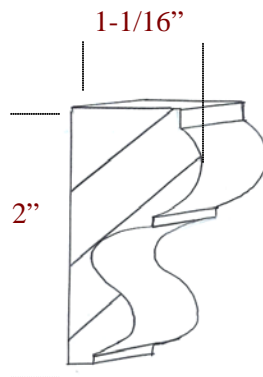

C-126

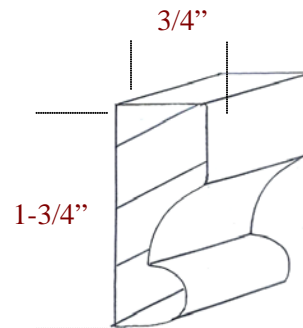

C-127

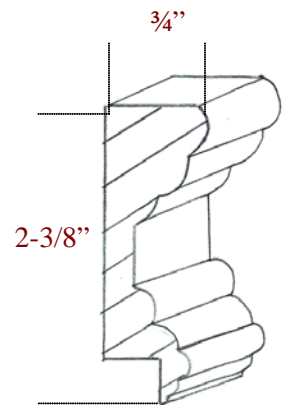

C-746

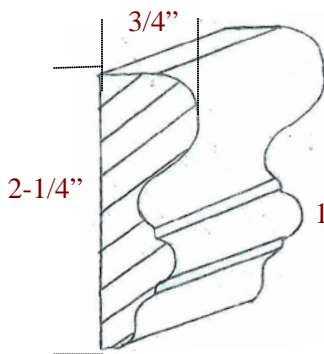

C-128

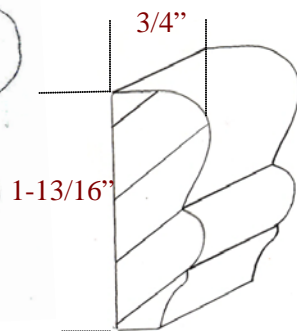

C-129



\*

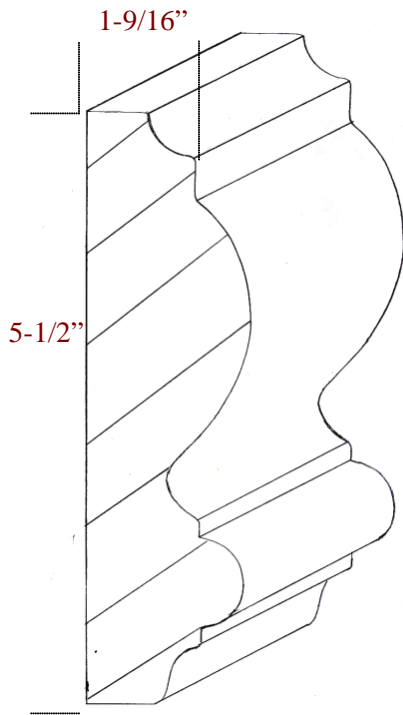
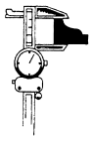

C-131

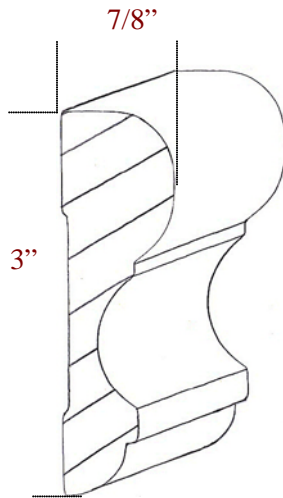

C-132

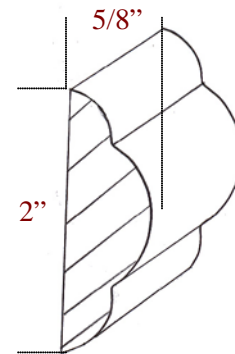

C-133

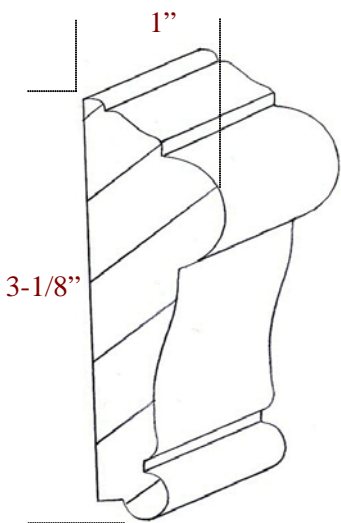

C-134

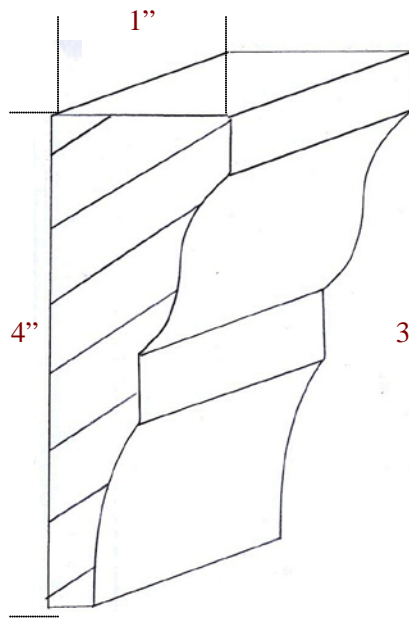

C-135

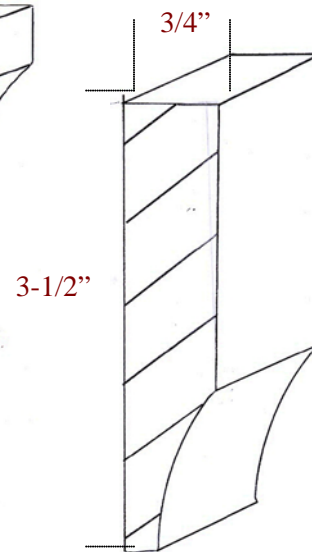

C-136

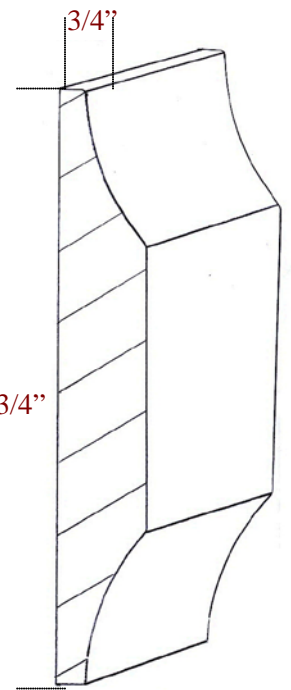

C-137

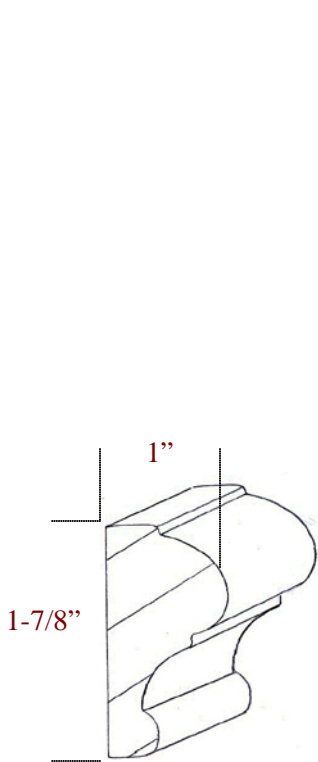

C-138

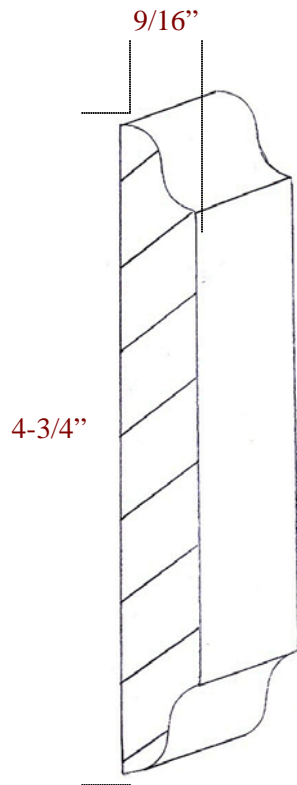

C-139

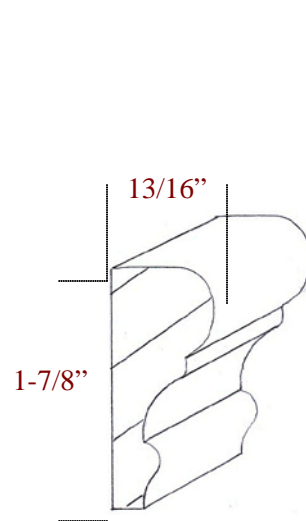

C-140

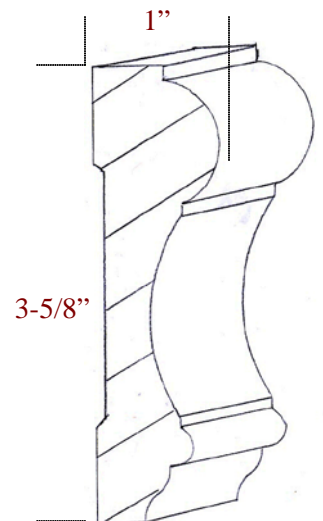

C-141

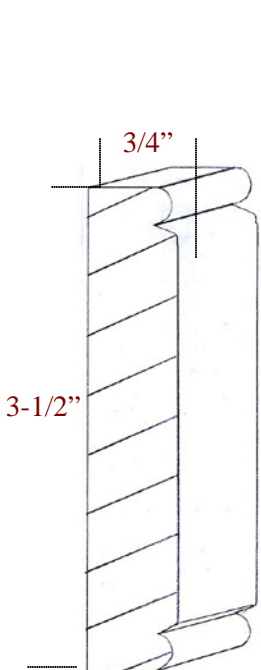

S-142

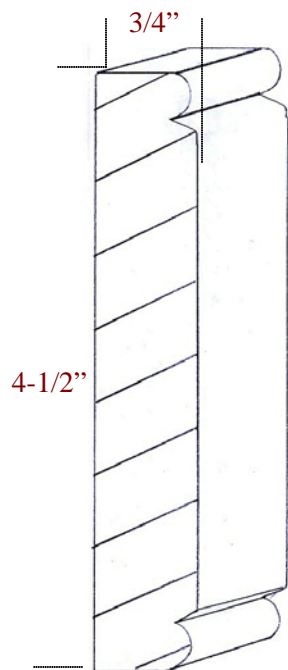

S-143

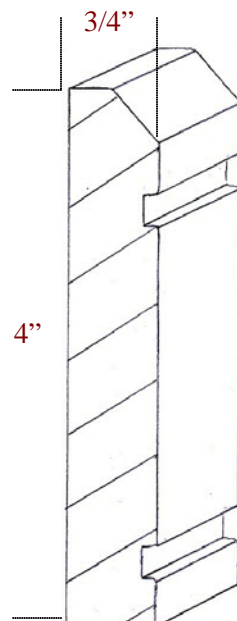

C-145

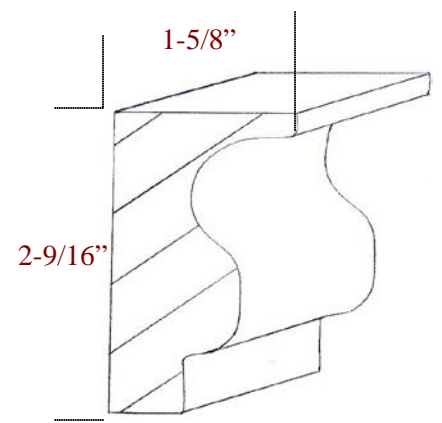

C-146

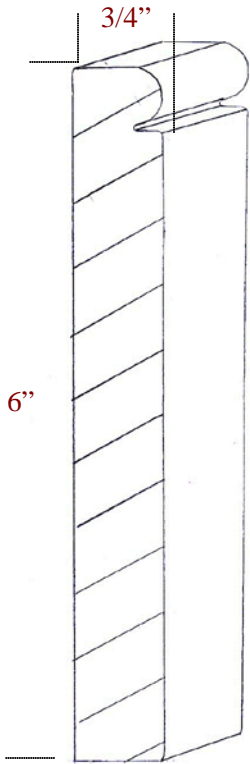

C-147

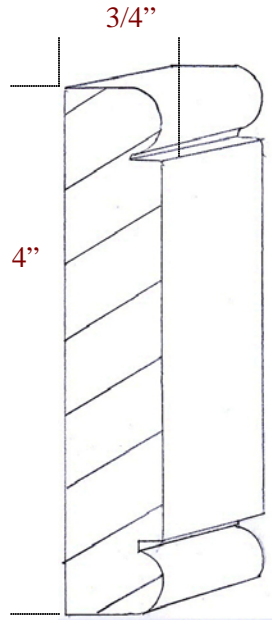

C-147A

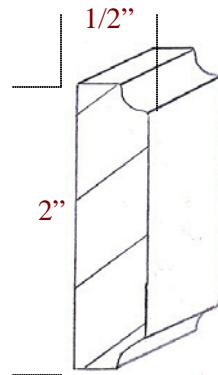

C-148

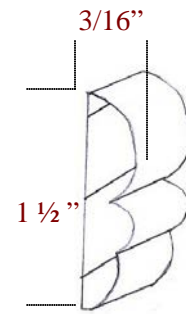

C-149

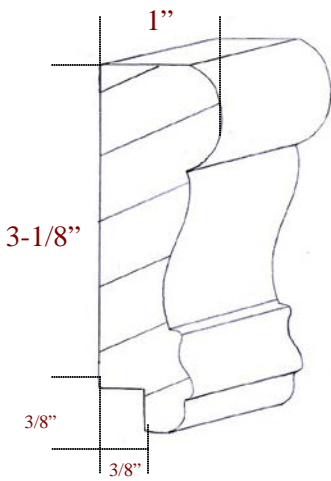

C-113A

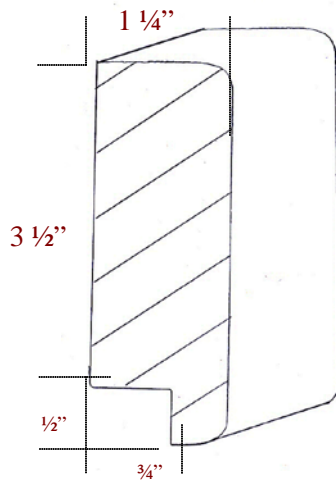

C-150

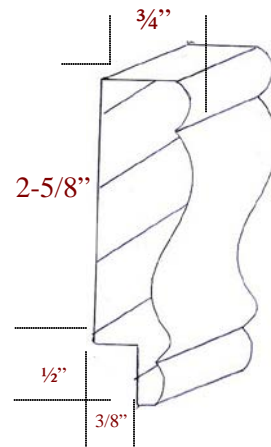

C-151

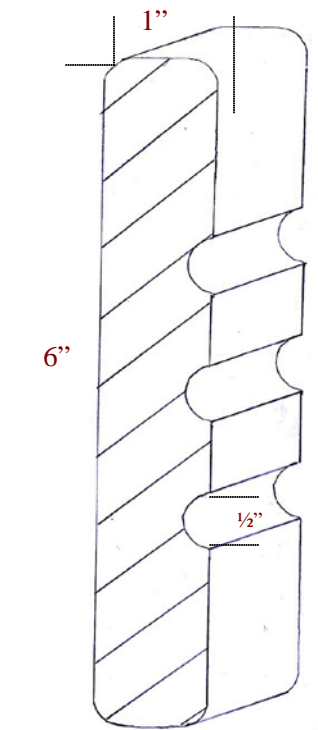

C-153

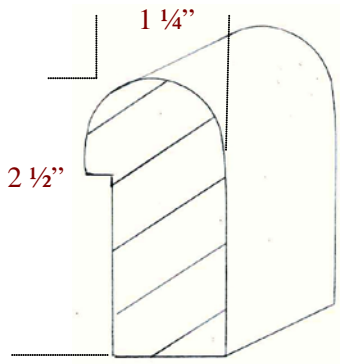
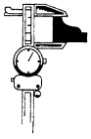

C-154

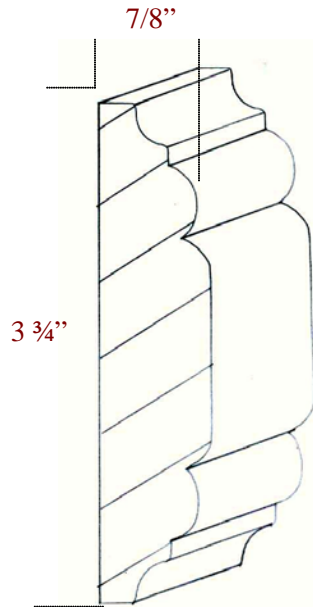

S-155

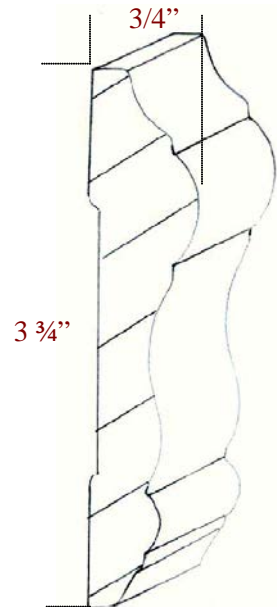

C-156